

# DJW SERIES

## DJW12-1.2 (12V1.2Ah)

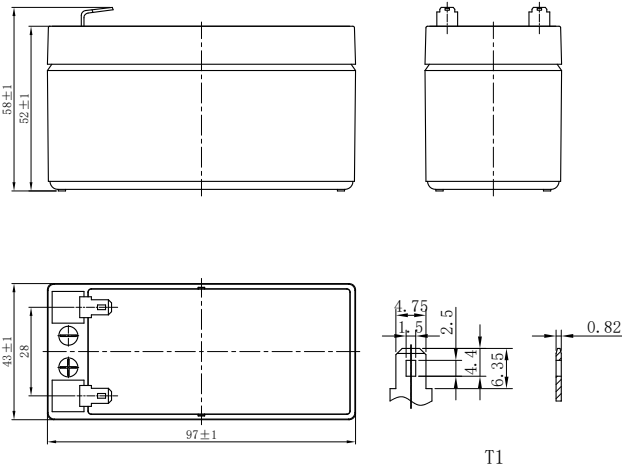

### CHARACTERISTICS

Item	Specifications	
Rated Voltage	12V	
Nominal Capacity (25°C)	C <sub>20</sub> : 1.75V/cell	1.2Ah
Dimension	Length	97mm (3.82inches)
	Width	43mm (1.69inches)
	Container Height	52mm (2.05inches)
	Total Height	58mm (2.28inches)
Approx Weight	0.57kg (1.26lbs)	
Terminal	T1	
Container Material	ABS (UL94 HB or V-0 optional)	
Short-circuit current	33.6A	
Internal Resistance (25°C)	Approx 115 mΩ (Fully charged)	
Operating Temp. Range	Discharge	-15~50°C (5~122°F)
	Charge	-20~40°C (-4~104°F)
	Storage	-15~40°C (5~104°F)
Nominal Operating Temp. Range	25±3°C (77±5°F)	
Max. Charging Current (25°C)	0.3C	
Charge voltage (25°C)	Standby Use	Cycle Use
	2.25-2.30V/cell	2.35-2.45V/cell
Temp. Coefficient	-3mV/cell/°C	
	-5mV/cell/°C	
Effect of temp. to Capacity	40°C (104°F)	103%
	25°C (77°F)	100%
	0°C (32°F)	86%
Self Discharge	≤3% per month at 25°C (77°F). DJW series batteries may be stored up to 6 months at 25°C (77°F) and then a freshening charge is required. For higher temperatures the time interval will be shorter.	

### DISCHARGE TABLE

Constant Current Discharge (Amperes) at 25°C (77°F)																
F.V/Time	5min	10min	15min	20min	30min	45min	1h	1.5h	2h	3h	4h	5h	6h	8h	10h	20h
1.85V/cell	3.73	2.28	1.78	1.48	1.10	0.813	0.714	0.523	0.411	0.296	0.236	0.201	0.172	0.136	0.111	0.059
1.80V/cell	4.01	2.42	1.86	1.54	1.14	0.835	0.731	0.534	0.418	0.301	0.240	0.204	0.175	0.138	0.112	0.059
1.75V/cell	4.23	2.52	1.92	1.59	1.17	0.853	0.746	0.543	0.426	0.306	0.243	0.207	0.177	0.139	0.113	0.060
1.70V/cell	4.43	2.62	1.99	1.63	1.20	0.872	0.760	0.553	0.432	0.311	0.246	0.209	0.179	0.141	0.115	0.060
1.67V/cell	4.58	2.69	2.04	1.67	1.22	0.886	0.771	0.560	0.437	0.314	0.249	0.211	0.181	0.142	0.115	0.061
1.60V/cell	4.86	2.80	2.11	1.72	1.25	0.908	0.789	0.572	0.446	0.319	0.253	0.215	0.183	0.144	0.117	0.062
Constant Power Discharge (Watts/cell) at 25°C (77°F)																
F.V/Time	5min	10min	15min	20min	30min	45min	1h	1.5h	2h	3h	4h	5h	6h	8h	10h	20h
1.85V/cell	7.06	4.34	3.40	2.86	2.13	1.58	1.39	1.02	0.804	0.583	0.465	0.397	0.341	0.269	0.220	0.117
1.80V/cell	7.52	4.57	3.55	2.96	2.19	1.61	1.42	1.04	0.817	0.591	0.471	0.402	0.345	0.273	0.223	0.119
1.75V/cell	7.84	4.72	3.64	3.02	2.23	1.64	1.44	1.05	0.830	0.599	0.477	0.407	0.349	0.275	0.225	0.120
1.70V/cell	8.13	4.87	3.74	3.09	2.28	1.67	1.46	1.07	0.840	0.607	0.483	0.412	0.353	0.278	0.227	0.121
1.67V/cell	8.34	4.98	3.82	3.15	2.32	1.70	1.48	1.08	0.848	0.612	0.487	0.415	0.356	0.280	0.229	0.122
1.60V/cell	8.68	5.13	3.92	3.23	2.37	1.73	1.51	1.10	0.862	0.621	0.494	0.420	0.360	0.284	0.232	0.123

# DJW SERIES

## DJW12-1.2 (12V1.2Ah)



### APPLICATIONS

- Uninterruptable Power Supply (UPS)
- Electric Power System (EPS)
- Emergency backup power supply
- Alarm and security system
- Communication power supply
- DC power supply
- Auto control system

### GENERAL FEATURES

- 5 years design life (25°C)
- Lead calcium alloy, sealed design, no watering required
- Puncture resistant micro-porous glass mat separators extend life
- Unique technology optimizes power capacity, cell consistency, and long-term reliability
- Designed for a wide range of applications

### STANDARDS

- Compliance with IEC 60896 standards, EU Battery Directive
- UL, CE Approved
- Manufactured in Leoch@IATF 16949, ISO 45001, ISO 9001 and ISO 14001 certified production facilities

#### Discharge Characteristics

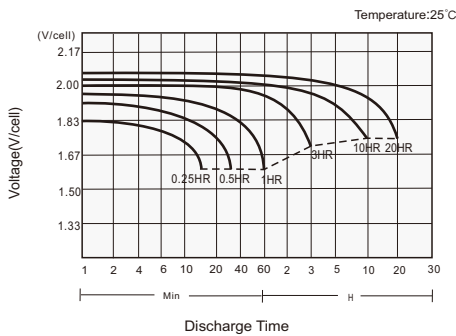

#### Charging Characteristics

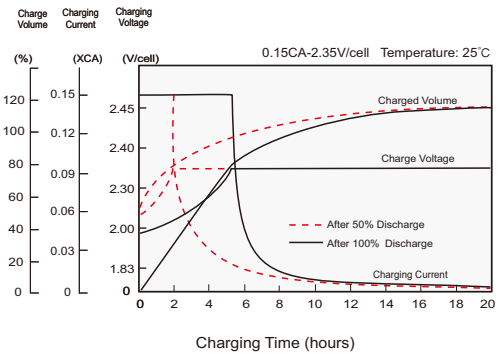

#### Effects of Temperature on Capacity

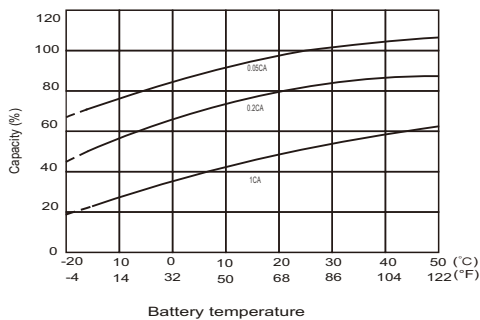

#### Self Discharge Characteristics

